

MINIATURE SLIDE

The NB miniature slide SYBS type is a limited stroke table with the most compact envelope dimensions, featuring two ball raceway grooves. The SYBS type utilizes balls as the rolling elements. The ultra compact design contributes greatly to the creation of smaller and lighter industrial machinery and equipment of all types.

STRUCTURE AND ADVANTAGES

The NB miniature slide incorporates a unique integrated ball cage between the table and bed. All components have been produced with high precision machining.

Ultra Compact Design

The table height of the SYBS type is 3.2~8mm and the width is 6~17mm. This compact size when compared with conventional slide tables helps to realize the miniaturization of machinery and equipment.

Low Friction · Low Noise

Since the rolling ball elements do not recirculate, the frictional resistance will not vary significantly resulting in smooth, high precision operation. Additionally, the

ball cage greatly reduces the contact noise of the rolling elements bringing about a low-noise operation.

High Accuracy

The ball raceway grooves of each of the bed and table are processed through simultaneous precision machining resulting in minimal processing errors, and bringing about extremely smooth, precision linear movement.

Stainless Steel Structure

The SYBS type is made of all stainless steel components. This allows for use in corrosive or high temperature applications. The SYBS is a perfect component for vacuum or clean room environments,

Figure A-24 Structure of SYBS type

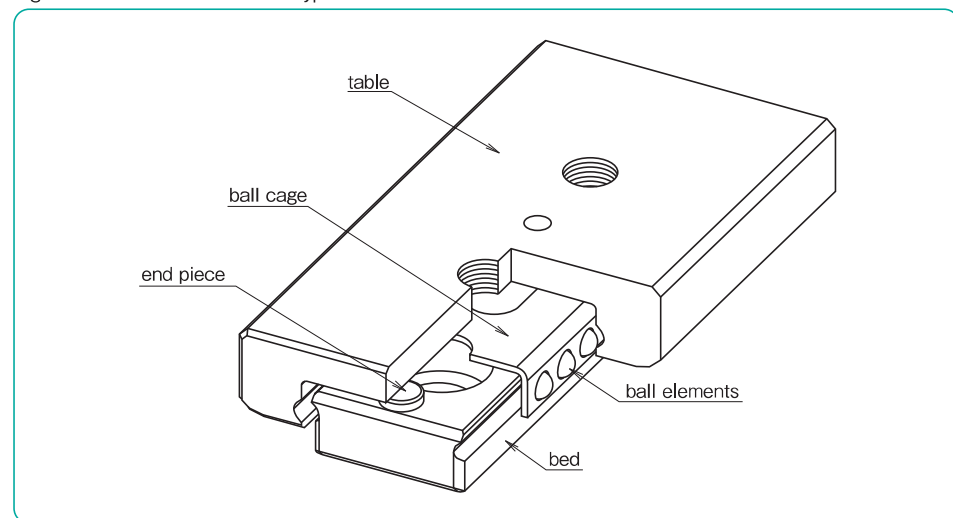

SPECIFICATION

Refer to table A-10 for NB Miniature Slide material and operating temperature range.

Table A-10 Material and Operating Temperature Range

type	table/bed	ball cage	ball elements	operating temperature range
SYBS	stainless steel	stainless steel	stainless steel	-20°C~140°C

ACCURACY

Table A-11 shows the accuracy of the SYBS miniature slide.

The deviation is measured as Figure A-25 illustrates. Dial indicators are placed to the center of the table's top and the reference surface side (opposite from the NB mark) and then the table is moved the full stroke without any load.

Table A-11 Accuracy unit : mm

item	tolerance
height H	±0.020
width W	±0.025
deviation from center of surface C	0.004
deviation from center of surface D	0.006

Figure A-25 Accuracy Measurement Method

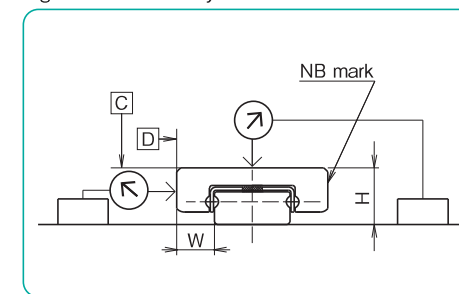

LOAD RATING

The load rating of the miniature slide varies depending on the direction of the applied load.

Table A-12 Change of Load Rating Corresponding to Load Direction

basic dynamic load rating	vertical direction	1.00×C
load rating	horizontal direction	1.19×C
basic static load rating	vertical direction	1.00×Co
load rating	horizontal direction	1.19×Co

Figure A-26 Direction of Load

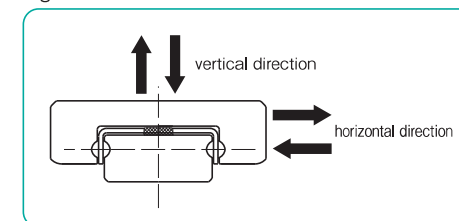

RATED LIFE

The life of an NB miniature slide is calculated using the following equations:

Rated Life

$$L = \left(\frac{f_r}{f_w} \cdot \frac{C}{P} \right)^3 \cdot 50$$

L: rated life (km) f_r: temperature coefficient
f_w: applied load coefficient C: basic dynamic load rating (N)
P: applied load (N)

* Refer to page Eng-6 for the coefficient.

Life Time

$$L_h = \frac{L \cdot 10^6}{2 \cdot l_s \cdot n_i \cdot 60}$$

L_h: life time (hr) l_s: stroke length (mm)
n_i: number of cycles per minute (cpm)

MOUNTING

Mounting Surface Profile

In most general installations, the miniature slide is mounted by pushing the reference surface of the bed and table against a shoulder that is set up on the mounting surface. Machined undercuts should be used in the corners of the shoulder (as illustrated in Figure A-27) so that the corners will not interfere with the reference surfaces of the bed and table. Table A-13 lists the recommended shoulder heights of the mounting reference surfaces.

When installing the miniature slide table without providing machined undercuts, the corner radius should be realigned as illustrated in Figure A-28. Table A-14 lists the values of the corner radius of the mounting surface.

Figure A-27 Mounting Surface Profile-1

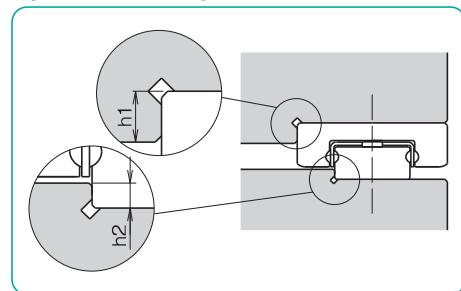

Table A-13 Shoulder Height on Mounting Reference Surface
unit : mm

part number	shoulder height for table h1	shoulder height for bed h2
SYBS 6	1.0	0.5
SYBS 8	1.2	0.8
SYBS12	1.5	0.8
SYBS17	2.5	1

Figure A-28 Mounting Surface Profile-2

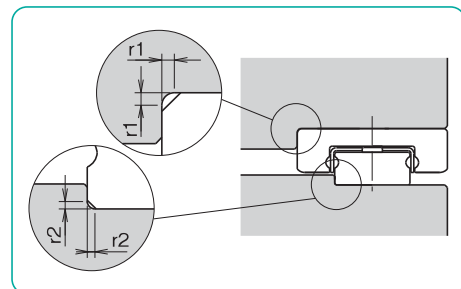

Table A-14 Maximum Corner Radius
unit : mm

part number	mounting surface for table	mounting surface for bed
	r1	r2
SYBS 6	0.1	0.05
SYBS 8	0.15	0.1
SYBS12	0.15	0.1
SYBS17	0.3	0.3

Recommended Torque Value

The bed should be tightened with a consistent torque by using a torque wrench. Table A-15 lists the recommended torque.

Table A-15 Recommended Torque
unit : N · m

size	torque
M1	0.03
M1.6	0.15
M2	0.3

(for stainless steel screw A2-70)

Figure A-29 Profile of SYBS Bed

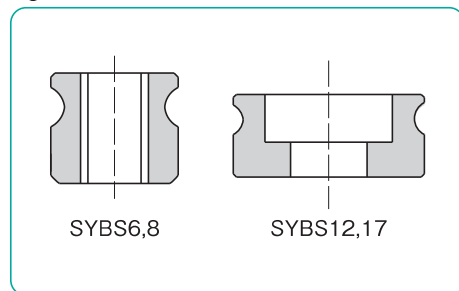

Mounting Example and Mounting Screw

All the mounting holes are for SYBS6,8,12 fully through-hole. Mount SYBS6,8,12 as illustrated in Figure A-30 after considering the size of mounting screw, the maximum penetration depth, and the height of the bed. Make certain that the mounting screws do not interfere with the ball cage; otherwise, the accuracy and travel life will be affected adversely. Special screws for SYBS type are available from NB. Please refer to Table A-16 for dimensions of mounting screws.

Figure A-30 Mounting Example

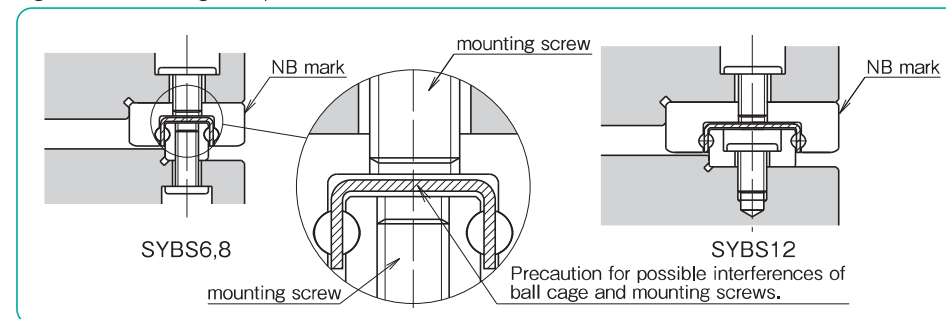
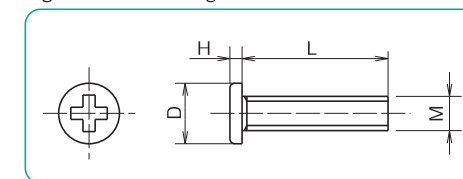

Table A-16 Mounting Screw (stainless steel)

M (size)	D mm	H mm	pitch mm	L mm
M1	1.8	0.45	0.25	5
M1.4	2.5	0.5	0.3	6
M1.6	2.3	0.5	0.35	4, 5, 6
M2	3	0.6	0.4	6

Figure A-31 Mounting Screw



USE AND HANDLING PRECAUTIONS

Preload

The SYBS miniature slide is provided with a slightly positive clearance type only.

End Piece

On both ends of the SYBS miniature slide bed section, screws are attached to prevent the ball cage from escaping. Please note that the screws are designed only to prevent the ball cage from escaping and are not intended for the use as a mechanical stopper. The ball cage may become deformed on contact with the stopper and this will result in a negative affect of the accuracy and travel life.

Lubrication

NB miniature slide SYBS type is supplied with an initial application of lithium soap grease No.0 and therefore is ready for immediate use. Make sure to

relubricate with a similar type of grease periodically according to the operating conditions. For use in clean rooms or vacuum environments, miniature slide tables without grease or with customer specified grease are available. NB also provides low dust generation grease. Please refer to page Eng-51 for details.

Cage Slippage

For the SYBS type, the cage can slip under high-speed motion, vertical application, unbalanced-loading, and vibrating conditions. It is advised that the motion speed be kept under 0.5m/s under general operating conditions. It is also recommended that the table be cycled to perform the maximum stroke several times, so that the cage returns to its center position.

SYBS TYPE

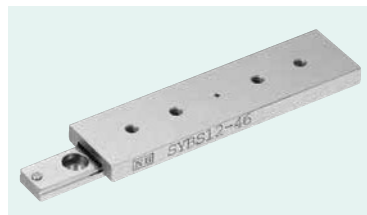

part number structure

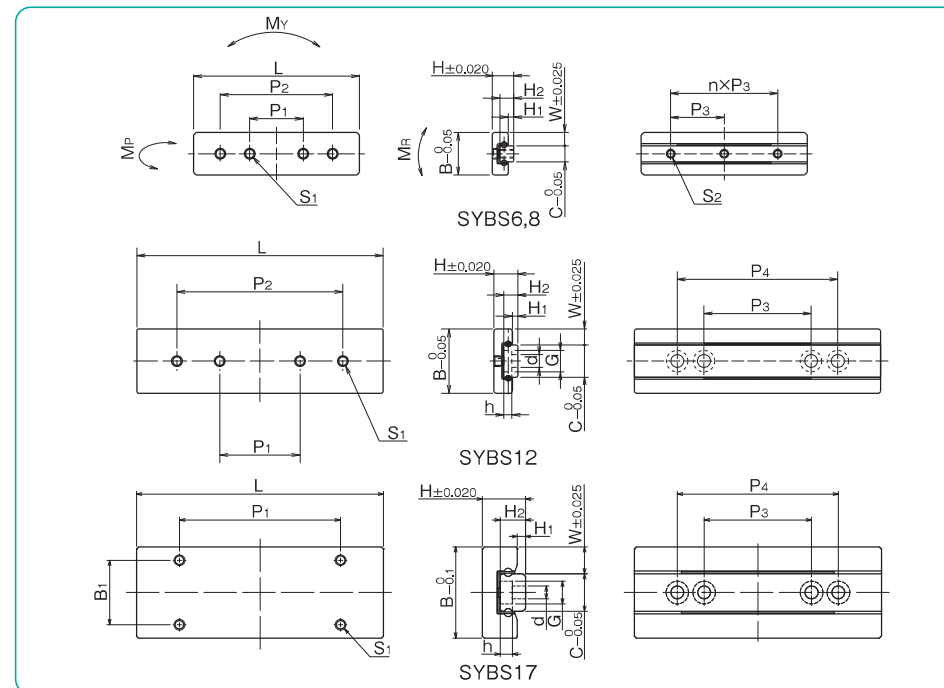
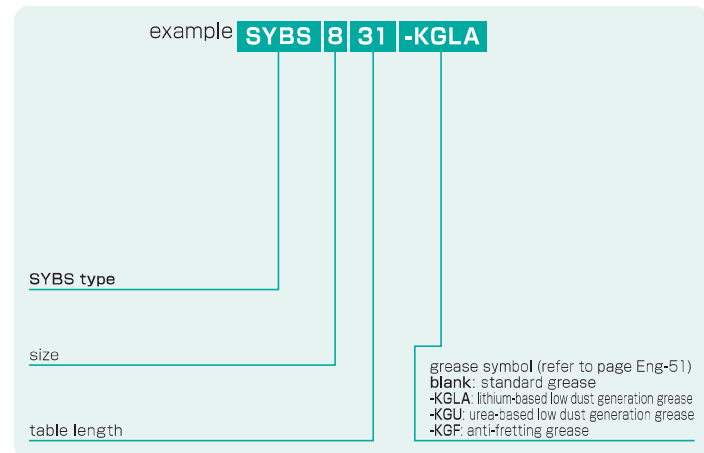

part number	major dimensions				tabel-top dimensions						S ₁ maximum screw penetration depth mm	
	H mm	W mm	H ₁ mm	stroke mm	B mm	L mm	P ₁ mm	P ₂ mm	B ₁ mm			
SYBS 6-13	3.2	2	0.7	5	6	13	6	—	—	M1.4	0.5	
SYBS 6-21				12		21	10	—	—			
SYBS 8-11	4	2.5	1	4	8	11	5.5	—	—	M1.6	0.7	
SYBS 8-21				12		21	10	—	—			
SYBS 8-31				18		31	10	21	—			—
SYBS12-23	4.5	3	1	12	12	23	8	—	—	M2	1.2	
SYBS12-31				18		31	15	—	—			
SYBS12-46				28		46	15	31	—			—
SYBS17-23				14		23	10	—	—			—
SYBS17-31	8	5	1.5	19	17	31	20	—	12	M2	3	
SYBS17-46				29		46	30	—	—			

※1: Custom mounting screws are provided with the SYBS-12 type only. Other screw sizes are also available. (Please refer to page A-67)

SYBS12 bed mounting screw

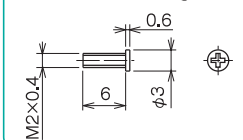

H ₂ mm	C mm	bed-surface dimensions				basic load rating		allowable static moment			mass g	size	
		d×G×h mm	S ₂	P ₃ mm	n mm	P ₄ mm	dynamic C N	static C ₀ N	M _P N·m	M _Y N·m			M _R N·m
2.0	2	—	M1	7	1	—	154	180	0.21	0.25	0.21	1.4	6-13
				7	2	—	229	315	0.57	0.69	0.37	2.2	6-21
2.6	3	—	M1.6	5	1	—	201	211	0.23	0.28	0.35	2.0	8-11
				10	1	—	368	493	1.02	1.22	0.83	3.7	8-21
2.6	6	2.4×4×1.5 ^{※1}	—	10	2	—	473	704	1.97	2.35	1.19	5.5	8-31
				15	—	—	404	563	1.30	1.55	1.80	7.6	12-23
				15	—	—	473	704	1.97	2.35	2.25	10.2	12-31
				20	—	30	658	1,120	4.80	5.72	3.60	15.2	12-46
4.7	7	2.4×4.2×2.3	—	15	—	—	775	888	2.09	2.49	3.33	19.2	17-23
				15	—	—	984	1,240	3.80	4.53	4.66	26.2	17-31
				20	—	30	1,350	1,950	8.75	10.4	7.32	38.4	17-46

1N≒0.102kgf 1N·m≒0.102kgf·m